

Exponential U-to-I Converter for Frequency Control

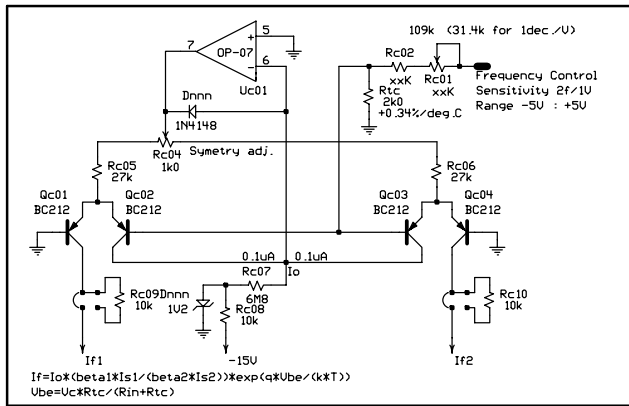

Phase Shifter - Single Stage

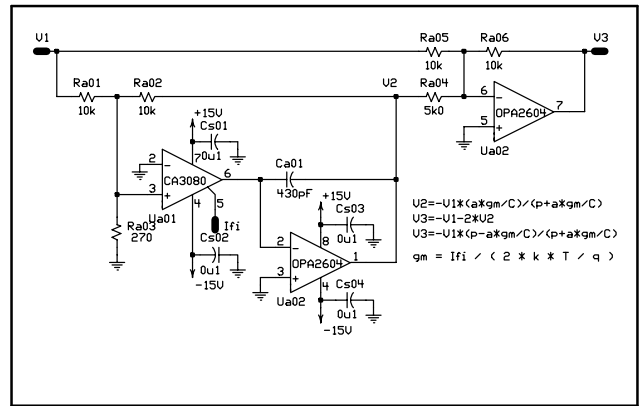

Amplitude Control Voltage Generation

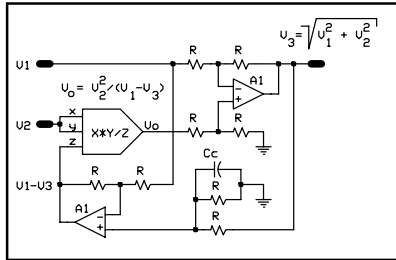

Multiplier & Divider (X*Y/Z)

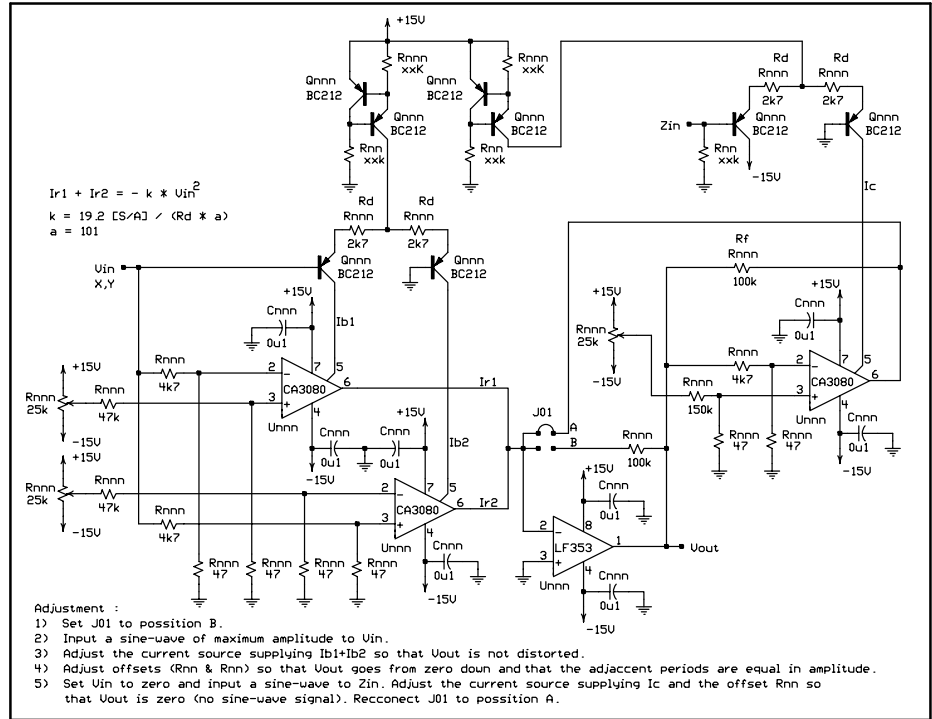

Differential Output Buffer

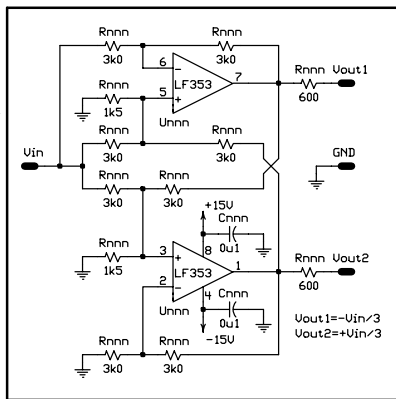

Amplitude Control

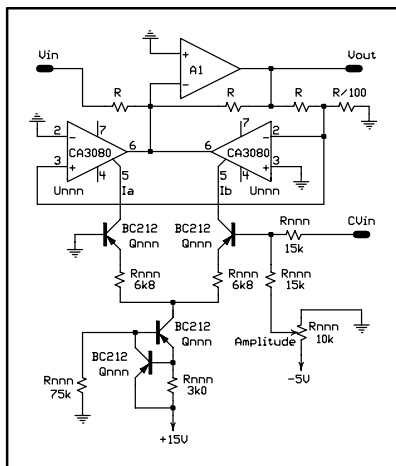

Phase-Shift Oscillator - the principle

