

The Speed and Decay of Cosmic-Ray Muons: Experiments in Relativistic Kinematics - The Universal Speed Limit and Time Dilation

MIT Department of Physics

The purpose of this experiment is to demonstrate 1) the existence of a speed limit on the motion of particles by a measurement of the speed of cosmic-ray muons, and 2) the relativistic dilation of time by a comparison of the mean life of muons at rest and in high speed motion.

PREPARATORY QUESTIONS

1. What are muons, how are they produced in the atmosphere, and why are the particularly penetrating particles (as opposed to electrons for example)?
2. Derive from the Lorentz transformation equations an expression for the mean life measured in the laboratory of unstable particles of a given kind traveling with kinetic energy K if their rest mass is m_0 and their mean life at rest is τ_0 . Assuming that the most likely momentum for the muon is approximately $1\text{GeV}/c$ (see Appendix C), calculate β , γ and the flight time for a trip of 3 meters (approximate flight path in this apparatus.)
3. A singly charged particle traveling in matter at nearly the velocity of light loses energy by Coulomb interactions with the atoms of matter at a rate of approximately $2\text{MeV}/(\text{gm}/\text{cm}^2)^{-1}$. (The denominator is an areal density and is equal to the volume density times the thickness). How much energy is lost by a relativistic particle ($v \approx c$) particle in traversing the entire atmosphere?
4. Describe how a scintillation counter works, starting from the entrance of an energetic charged particle into a scintillator, and ending with an electrical pulse at the output of the photomultiplier.
5. Suppose the rates of pulses from the top and middle scintillator “paddles” are n_1 and n_2 , respectively, due mostly to physically unrelated events in the two scintillators. Suppose further that the differences in arrival times at the time-to-amplitude converter (TAC) of pulses produced by muons traversing the paddles are spread over a time interval τ due to differences in the path lengths and jitter in the electronics. What is the rate of background events in this interval due to accidental near-coincidences between physically unrelated events? Now suppose that $n_1 = n_2 = n$, and $\tau = 1.0 \times 10^{-8}$ s. If the rate of muon traversals of the two paddles when they are separated as far as possible is 0.1 s^{-1} , how large a value of n could be tolerated?
6. The weight of the cylinder of plastic scintillator used in the measurement of the muon mean life

is 20.3 kg. Predict the rate of muon decay events in the cylinder. (See Appendix A).

WHAT YOU WILL MEASURE

1. According to classical mechanics the speed of a particle is proportional to the square root of its kinetic energy. Since there is no limit, in principle, on the kinetic energy of a body, there is no classical speed limit. According to the theory of relativity there is a speed limit. In the first of these experiments you will measure the distribution in velocity of high energy muons that are generated high in the atmosphere through the interactions of primary cosmic ray nuclei and pass through the lab from ceiling to floor.
2. In the second experiment you will measure the decay curve and mean life of muons that have come to rest in a scintillator. Given your measured values of the speed limit and the mean life, and given the fact that most of the muons are produced at altitudes above 10 km, you will confront the fact that the muons that traverse the scintillator paddles survived much longer than the mean life of muons at rest in the laboratory. How is that possible?

INTRODUCTION

Webster’s Ninth New Collegiate dictionary defines kinematics as “a branch of dynamics that deals with aspects of motion apart from considerations of mass and force”. Relativistic kinematics deals with motion at speeds approaching that of light. These experiments are concerned with phenomena of high speed kinematics - the distribution in speed of very high energy particles, and the comparative rates of clocks at rest and in high speed motion.

Common sense, based on experience with comparatively slow motions, is a poor guide to an understanding of high speed phenomena. For example, in classical kinematics velocities add linearly in accordance with the Galilean transformation which implies no limit, in principle, to the relative velocities of two bodies. On the other

hand, Maxwell's equations have solutions in the form of waves that travel in vacuum with the universal velocity c , without regard to the motion of the source or observer of the waves. Thus, until Einstein straightened things out in 1905 in his special theory of relativity, there was lurking in the kinematical foundations of physics, as embodied in Newtonian mechanics and the Maxwell theory of electromagnetism, a fundamental contradiction.

This contradiction was laid bare in interferometry experiments begun by Michelson in 1881 which demonstrated the absence of any detectable effect of the motion of an observer on the velocity of light. Apparently without knowing about the Michelson experiment, Einstein took this crucial fact for granted when he began to think about the problem in 1895 at the age of sixteen (Pais, 1982). Ten years later he discovered the way to fix the contradiction; keep Maxwell's equations intact and modify Galilean kinematics and Newtonian dynamics. The fundamental problem of kinematics is to find the relations between measurements of space, time and motion in different reference frames moving with respect to one another.

Consider, for example, two events (think of two flash bombs, or the creation and decay of a muon) that occur on the common x-axes of two mutually aligned inertial coordinate systems A and B in uniform motion relative to one another in the direction of their x-axes. Each event is characterized by its four coordinates of position and time, which will, in general, be different in the two frames. Let x_a, y_a, z_a, t_a represent the differences between the coordinates of the two events in the A frame, i.e., the components of the 4-displacement. Similarly, x_b, y_b, z_b, t_b are the components of the 4-displacement in the B frame. According to the Galilean transformation of classical mechanics the components of the 4-displacement in A and B are related by the simple equations

$$x_b = x_a - vt_a, \quad y_b = y_a, \quad z_b = z_a, \quad t_b = t_a \quad (1)$$

and their inverse

$$x_a = x_b + vt_b, \quad y_a = y_b, \quad z_a = z_b, \quad t_a = t_b \quad (2)$$

where v is the velocity of frame B relative to frame A. If the two events are, in fact, two flash bombs detonated at a particular location in a third coordinate system (think of a rocket ship carrying the bombs) traveling in the x -direction with velocity u relative to B, then

$$x_b/t_b = u \text{ and } x_a/t_a = u + v \quad (3)$$

i.e., the velocity of the rocket ship relative to A is the sum of its velocity relative to B and the velocity of B relative to A. This simple result accords with common sense based on experience with velocities that are small

compared to c , the speed of light. Clearly, it implies no limit on the velocity of one body relative to another and assigns no special significance to any particular velocity. For example, if $u = 0.9c$ and $v = 0.9c$, then $x_a/t_a = 1.8c$. According to the special theory of relativity such a "superluminal" velocity is impossible because kinematics is actually governed by the transformation equations

$$x_b = \gamma(x_a - \beta ct_a), \quad y_b = y_a, \quad z_b = z_a, \quad ct_b = \gamma(ct_a - \beta x_a), \quad (4)$$

and their inverse

$$x_a = \gamma(x_b + \beta ct_b), \quad y_a = y_b, \quad z_a = z_b, \quad ct_a = \gamma(ct_b + \beta x_b), \quad (5)$$

where $\beta = v/c$ and $\gamma = 1/\sqrt{1 - \beta^2}$. We obtain the addition equation for velocities, as before, by dividing the equations for x_a and t_a . Thus

$$x_a/t_a = (u + v)/(1 + uv/c^2) \quad (6)$$

Now, if $u = 0.9c$ and $v = 0.9c$, then $x_a/t_a = 0.9945c$. No compounding of velocities less than c can yield a relative velocity of two bodies that exceeds c . Moreover, any entity that propagates with velocity c (i.e., massless particles such as photons, gravitons, and probably neutrinos) relative to one inertial reference frame will propagate with velocity c relative to every other inertial frame regardless of the motions of the frames relative to one another. Thus the velocity of light in vacuum is raised to the status of a universal constant - the absolute speed limit of the universe. The first experiment will demonstrate the consequences of this fact of relativity for the distribution in velocity of high-energy cosmic-ray muons.

Consider what these equations imply about different observations of the time interval between two events such as that between two flash bombs or between the birth and death of a particle or person. Suppose a rocket ship carrying two flash bombs is at rest in frame B so that the bombs go off at the same position in B ($x_b = 0$) with a separation in time of t_b . Then $t_a = \gamma t_b$, i.e. as measured in frame A the time interval between the two events is longer by the Lorentz factor γ . This is the relativistic dilation of time.

COSMIC RAYS

Interstellar space is populated with extremely rarefied neutral and ionized gas ($\approx 10^{-3}$ to 10^3 atoms cm^{-2}), dust (≈ 1 -10% of gas), photons, neutrinos, and high-energy charged particles consisting of electrons and bare nuclei of the elements with energies per particle ranging up to 10^{21} eV. The latter, called cosmic rays, constitute a relativistic gas that pervades the galaxy and significantly affects its chemical and physical evolution. The elemental composition of cosmic-ray nuclei resembles that of the

sun, but with certain peculiarities that are clues to their origins. Most cosmic rays are generated in our galaxy, primarily in supernova explosions, and are confined to the galaxy by a pervasive galactic magnetic field of several microgauss. It is an interesting and significant fact that the average energy densities of cosmic rays, the interstellar magnetic field, and turbulent motion of the interstellar gas are all of the order of 1 eV cm^{-3} .

When a primary cosmic ray (most often a proton or alpha particle) impinges on the earth's atmosphere it interacts with an air nucleus, generally above an altitude of 15 km. Such an interaction initiates a cascade of high-energy nuclear and electromagnetic interactions that produce an "air shower" of energetic particles spreading outward in a cylindrically symmetric pattern around a dense core. See Figure 1. As the shower propagates downward through the atmosphere the energy of the incident and secondary hadrons (nucleons, antinucleons, pions, kaons, etc.) is gradually transferred to leptons (weakly interacting muons, electrons and neutrinos) and gamma rays (high-energy photons) so that at sea level the latter are the principal components of "secondary" cosmic rays. Typical events in such a cascade are represented by the reactions shown in Figure 1. High altitude observations show that most of the muons that arrive at sea level are created above 15 km. At the speed of light their trip takes $\approx 50 \mu\text{sec}$.

In 1932, Bruno Rossi, using Geiger tubes and his own invention, the triode coincidence circuit (the first practical AND circuit), discovered the presence in cosmic rays of highly penetrating and ionizing (i.e. charged) particles that were shown in 1936 by Anderson and Nedermeyer to have a mass intermediate between the masses of the electron and the proton. In 1940 Rossi showed that these particles, now called muons, decay in flight through the atmosphere with a mean life in their rest frame of about 2 microseconds. Three years later, using another electronic device of his invention, the time to pulse-height converter (TAC), he measured the mean life of muons at rest in an experiment resembling the present one in Junior Lab, but with Geiger tubes instead of a scintillation detector.

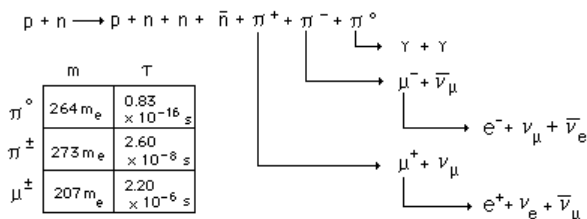

FIG. 1: (a) Production and decay of pions and muons in a representative high energy interaction of a cosmic-ray proton with a neutron in the nucleus of an air atom. (b) Masses and lifetimes of pions and muons.

Cosmic rays are a convenient and free source of energetic particles for high energy physics experiments. They suffer the disadvantage of being a mixed bag of uncollimated particles of various kinds with low intensity and a very broad range of energies. Nevertheless, the highest energy of a cosmic-ray primary measured so far, $\approx 10^{21} \text{ eV}$, exceeds by many orders of magnitude the practical limit of any existing or conceivable man-made accelerator. Cosmic rays will therefore always be the only source of particles for the study of interactions at the highest observable energies. In the present experiment they will be used to explore relativistic kinematics at the comparatively modest energies of a few GeV ($1 \text{ GeV} = 10^9 \text{ eV}$), which are the typical energies of the muons detected at sea level.

THE SPEED DISTRIBUTION OF COSMIC-RAY MUONS

According to Newtonian mechanics the velocity of a particle is related to its energy and mass by the equation

$$v = \sqrt{2E/m} = c\sqrt{2E/mc^2}. \quad (7)$$

For the muon the value of mc^2 is 105.7 MeV. Thus the Newtonian prediction for the velocity of a 1 GeV muon is approximately 4.3c. According to relativistic mechanics the higher the energy of a particle the closer its speed approaches c. Thus an observation of the distribution in speed of high-energy cosmic-ray muons provides a dramatic test of the relation between energy and velocity. The experiment consists of a measurement of the difference in the median time of flight of muons between two detectors in the form of plastic scintillator "paddles" when they are close together and far apart.

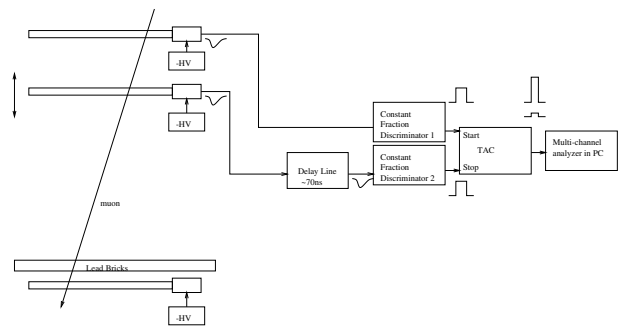

FIG. 2: (a) Arrangement for measuring the speed of cosmic-ray muons.

The setup is shown in Figure 2. The measurement can be made either between the top and middle detector (with no lead absorber) or between the middle and bottom detector with a lead absorber to block the passage of the so-called "soft" component (electrons and photons)

and low energy muons near the end of their range when they traverse the detectors. The signal from the top (or bottom) detector generates the start pulse for the time-to-amplitude converter (TAC). The pulse from middle detector, after appropriate delay in a long cable, generates the STOP pulse. A multi-channel analyzer (MCA) records the amplitude of the positive output pulse of the TAC; that amplitude is proportional to the time interval between the input start and stop pulses. The median value of this interval for many events changes when the middle detector is moved from the top to the bottom position. The change in the median value is a measure of the median time of flight of the detected muons and, given the distance between the top and bottom positions of the middle paddle, of the median velocity.

PROCEDURE

Throughout the setup procedure it is essential to use the fast oscilloscope to check the signs, amplitudes, occurrence rates and timing relationships of the pulses into and out of each component of the electronic system. Since you are aiming to measure time differences of the order of the travel time of light from the ceiling to the floor (≈ 10 nanosec), all the circuits up to the MCA must have “rise times” substantially shorter, which means that you must use very high sweep speeds on the oscilloscope in order to perceive whether things are behaving properly. To avoid confusing reflections from the ends of cables, it is essential that all cables carrying fast pulses be terminated at their outputs by their characteristic impedance of 50 ohms, either with a terminating plug on a T-connector, or by an internal termination at the input of a circuit.

To check the reasonableness of the various rates of single and coincident pulses you can use the following empirical formula that provides a good fit to measurements of the intensity of penetrating particles at sea level as a function of the zenith angle:

$$I(\phi) = I_v \cos^2(\phi), \quad (8)$$

where $I_v = 0.83 \times 10^{-2} \text{ cm}^{-2} \text{ s}^{-1} \text{ str}^{-1}$, and ϕ is the zenith angle (Rossi 1948). $I(\phi)d\Omega dA dt$ represents the number of particles incident upon an element of area dA during the time dt within the element of solid angle $d\Omega$ from the direction perpendicular to dA . By integrating this function over the appropriate solid angle you can estimate the expected counting rates of the detectors due to the total flux of penetrating particles from all directions, and the expected rate of coincident counts due to particles that arrive within the restricted solid angle defined by the telescope (See Appendix B).

Set the discriminator dials of the constant fraction discriminators (CFD) to 0.5 V. Adjust the high voltages

supplied to the photomultipliers (PM) of each of the detectors so that the rate of gate pulses from the CFD's is about 200 counts/s, roughly 5 times the rate of muon traversals from all directions. This will achieve a high detection efficiency for muon pulses including those buried in the background of events due to local radioactivity.

Explore the operation of the TAC and the MCA with the aid of the time calibrator (TC). The TC produces pairs of fast negative pulses separated by multiples of a precise interval. When these pulses are fed to the START and STOP inputs of the TAC, the TAC produces output pulses with amplitudes proportional to the time intervals between the input pulses. The amplitudes are measured by the MCA.

With the aid of the TC, set the controls of the TAC and MCA so that the calibration of the system is approximately 20 MCA channels per nanosecond. Test the linearity of the time-to-height conversion. Calibrate the system so that you can relate accurately the difference between the numbers of any two channels on the MCA display to a change in the time interval between START and STOP pulses at the TAC.

Now feed the negative gate pulses from CFD1 and CFD2 to the start and stop inputs of the TAC, making sure you have them in the right order so that the stop pulse arrives at the stop input after the start pulse arrives at the start input, taking account of both the time of flight and the pulse transmission times in the cables. Connect the output of the TAC to the input of the MCA operating in the PHA mode. Adjust the delays and set the controls of the TAC and MCA so that the timing events generated by the muons are recorded around channel 500 of the MCA with a timing sensitivity of approximately 10 channels per nanosecond.

Accumulate on the MCA the distribution in duration of the time intervals between the START and STOP pulses when the middle detector is located near the top of the apparatus and again when it is near the bottom (don't waste time at intermediate positions).

Calibrate the time base with the TC. Do not alter any of the cabling or electronic settings between any pair of top and bottom measurements. Even a small change in a high voltage or the triggering level of a discriminator can change the timing by enough to introduce a large systematic error in a velocity determination.

Optional: If you want to explore the effect on the average speed of selecting muons with higher energy you can use the bottom detector in place of the top detector. Between the bottom and middle detectors there is a layer of lead bricks, which absorb low-energy, slow muons.

ANALYSIS

Keep in mind the fact that the measured quantities are not actual times of flight of muons between the up

and down positions of the middle detector. Rather, they are differences in arrival times of pulses from the top and middle detectors generated by flashes of scintillation light that have originated in various places within each scintillator paddle and have diffused at the speed of light in plastic to the photomultiplier window. Each event yields a quantity t_i that can be expressed as

$$t_i = t_0 + d_i/v_i + \Delta t_i, \quad (9)$$

where t_0 is a constant of the apparatus, d_i is the slant distance traveled by the i th muon between the top and middle detectors, v_i is the velocity of the muon, and Δt_i is the error in this particular measurement due to the difference in the diffusion times of the scintillation light to the two photomultipliers and other instrumental effects. (In this measurement it is reasonable to assume that the systematic error due to the timing calibration is negligible. Therefore we can deal directly with the t_i 's as the measured quantities rather than with the channel numbers of the events registered on the MCA.) Suppose we call T_u and T_d the mean values of the t_i 's in the up and down positions respectively. The simplest assumption is that

$$\Delta T = T_d - T_u = D/v, \quad (10)$$

where D is the difference in the mean slant distance traveled by the muons from the top to the middle paddle in the down and up positions, and v is the mean velocity of cosmic ray muons at sea level. Implicit in this is the assumption that $(\Delta t_i)_{av}$ is constant in both the up and down positions. Then v can be evaluated as

$$v = D/(T_d - T_u), \quad (11)$$

and the random error can be derived from the error in the means (i.e. in T_d and T_u) which can be figured according to the usual methods of error propagation (the error of a mean is the standard deviation divided by the square root of the number of events). An additional complication is due to the width of the timing curve. This width is of the same order of magnitude as the muon flight time in the apparatus for several reasons:

1. The time of flight between the two counters is given by Eq. (10), $\Delta T = T_d - T_u = D/v$. The cosmic ray muons have a momentum distribution given in Figure 9 in Appendix C. Using the experimental points in this figure estimate the dispersion in ΔT due to this effect.
2. The cosmic ray muons have a distribution of angles given by Eq. (8). This causes the distribution of distribution of flight paths D to differ in the "close" and "far" position. Estimate the dispersion in ΔT due to this effect. Take into account the dimensions of the detectors.

3. The cosmic ray muons hit the scintillators approximately uniformly. However the phototube is placed at one end of the scintillator. There is a dispersion in the time that a light pulse, created in the scintillator from the passage of the muons, hits the phototube. Estimate the dispersion in ΔT due to this effect, assuming that the index of refraction of the scintillator, $n \approx 1.5$.

Calibration of t_{ref} using an LED and two optical light fibers

There is a method to reduce the systematic error in this experiment. A light pulse from a LED is brought by two equal length optical fibers to the centers of the top and the movable scintillation counters. The light from the common LED feeding the fibers is simultaneous and corresponds to t_0 . The different propagation in the scintillators, the delays in the phototubes and cables will be the same as the signals from a muon traversing the counters on top of each other. Coming from an LED the pulses are more uniform than the muon induced signals and give a precise Gaussian peak in the time spectrum. The absolute accuracy is limited by the discriminator response to about 0.9 ns.

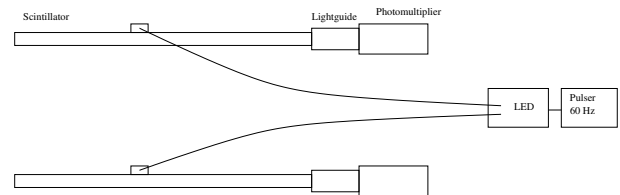

FIG. 3: Measurement of t_0 using simultaneous light pulses in two paddles

For smallest relative errors you still will measure the difference in the time-of-flight spectra between the counters close together and about 3m apart. The light pulse calibration provides the t_{ref} at the day you measure regardless of the relative position of the counters and a quick check that nothing has changed due to different cables, high voltage settings, etc. Before starting a TOF (time of flight) measurement simply turn on the pulse generator at the back wall and record the position of the peak which is t_0 . Adding a 2m length of "RG58/U" cable (the dielectric between the inner conductor and the outer conductor has $\kappa_e = 2.30$) into the signal path of the movable counter will shift the peak by 10ns and calibrates the channel bins into nanoseconds.

MEASUREMENT OF THE MEAN LIFE OF MUONS AT REST

Muons were the first elementary particles to be found unstable, i.e. subject to decay into other particles. At the time of Rossi's pioneering experiments on muon decay the only other "fundamental" particles known were photons, electrons and their antiparticles (positrons), protons, neutrons, and neutrinos. Since then dozens of particles and antiparticles have been discovered, and most of them are unstable. In fact, of all the particles that have been observed as isolated entities the only ones that live longer than muons are photons, electrons, protons, neutrons, neutrinos and their antiparticles. Even neutrons, when free, suffer beta (e^-) decay with a half life of ~ 15 minutes in the decay process

$$n \rightarrow p e^- \bar{\nu}_e.$$

Similarly, muons decay through the process

$$\mu^- \rightarrow e^- \bar{\nu}_e \nu_\mu$$

with a lifetime of $\tau^{-1} = \frac{G^2 m_\mu^5}{192\pi^3}$ in the Fermi β -decay theory, based on Figure 4 (a) which has become better understood in the modern electroweak theory, where the decay is mediated by heavy force carriers W .



FIG. 4: Feynman diagrams of the muon decay process

Muons can serve as clocks with which one can study the temporal aspects of kinematics at velocities approaching c where the strange consequences of relativity are encountered. Each muon clock, after its creation, yields one tick - its decay. The idea of this experiment is, in effect, to compare the mean time from the creation event to the decay event (i.e. the mean life) of muons at rest with the mean time for muons in motion. Suppose that a given muon at rest lasts for a time t_b . Equation 5 predicts that its life in a reference frame (See Figure 4 (a)) with respect to which it is moving with velocity v , is γt_b , i.e. greater than its rest life by the Lorentz factor γ . This is the effect called relativistic time dilation. (According to relativistic dynamics, γ is the ratio of the total energy of a particle to its rest mass energy).

In this experiment you will observe the radioactive decay of muons and measure their decay curve (distribution in lifetime) and their mean life after they have come to rest in a large block of plastic scintillator. From your previous measurement of the mean velocity of cosmic-ray muons at sea level and the known variation with altitude of their flux you can infer a lower limit on the mean life of the muons in motion. A comparison of the inferred

lower limit with the measured mean life at rest provides a vivid demonstration of relativistic time dilation. During the period from 1940 to 1950 observations of muons stopped in cloud chambers and nuclear emulsions demonstrated that the muon decays into an electron and that the energy of the resulting electron may have any value from zero to approximately half the rest energy of the muon, i.e. ≈ 50 MeV. From this it was concluded that in addition to an electron the decay products must include at least two other particles, both neutral and of very small or zero rest mass (why?). The decay schemes are shown in Figure (1).

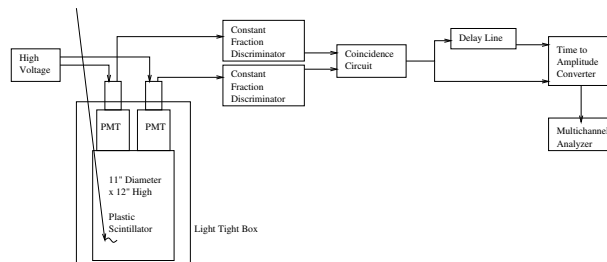

FIG. 5: Arrangement for measuring the mean life of muons

The experimental arrangement is illustrated in Figure 5. According to the range-energy relation for muons (see Rossi 1952, p40), a muon that comes to rest in 10 cm of plastic scintillator ($[CH_2]_n$ with a density of $\approx 1.2 g cm^3$) loses about 50 MeV along its path. The average energy deposited by the muon-decay electrons in the plastic is about 20 MeV. We want both START and STOP pulses for the TAC to be triggered by scintillation pulses large enough to be good candidates for muon-stopping and muon-decay events, and well above the flood of < 1 MeV events caused mostly by gamma rays and the "after" pulses that often occur in a photomultiplier after a strong pulse. The effect of "after-pulses" from the phototubes is eliminated by the use of two PM's and the coincidence requirement.

The success of the measurement depends critically on a proper choice of the discrimination levels set by the combination of the HV and the CFD settings. If they are too low, and the rate of accidental coincidences into the TAC is correspondingly too high, then the relatively rare muon decay events will be lost in a swamp of accidental delayed coincidences between random pulses. If the discrimination levels are too high, you will miss most of the real muon decay events. To arrive at a decision, review your prediction of the rate of decay events in the plastic cylinder. The answer to Preparatory Problem 5 tells you (implicitly) how to estimate the rate of accidental delayed coincidence events in which a random start pulse is followed by a random stop pulse within a time interval equal to, say, five muon mean lives. You want this rate of accidental events to be small compared to the rate of muon stoppings, allowing for reasonable inef-

efficiency in the detection of the muon decay events due to the variability of the conditions under which the muons stop and the decay electrons are ejected.

To avoid inhibiting the timing sequences by the simultaneous arrival of every pulse at the START and STOP inputs of the TAC the pulses to the START input must be delayed with a sufficient length of coaxial cable to insure that their effect at the STOP input is finished before the timing sequence is initiated. Every pulse that triggers the discriminator should start a timing sequence which will be stopped by the next pulse that arrives at the STOP input, provided it occurs before the end of the TAC timing ramp. What effect does this necessary delay of the start pulse and the consequent loss of short-lived events have on the mean life measurement?

A potential complication in this measurement is the fact that roughly half of the stopped muons are negative and therefore subject to capture in tightly bound orbits in the atoms of the scintillator. If the atom is carbon then the probability density inside the nucleus of a muon in a 1s state is sufficiently high that nuclear absorption can occur by the process (see Rossi, "High Energy Particles", p 186)



which competes with decay in destroying the muon. (Note the analogy with K- electron capture which can compete with positron emission in the radioactive decay of certain nuclei. Here, however, it is the radioactive decay of the muon with which the muon capture process competes.) The apparent mean life of the negative stopped muons is therefore shorter than that of the positive muons. Consequently the distribution in duration of the decay times of the combined sample of positive and negative muons is, in principle, the sum of two exponentials. Fortunately, the nuclear absorption rate in carbon is low so that its effect on the combined decay distribution is small.

PROCEDURE

Examine the outputs of the high gain photomultipliers with the oscilloscope. Adjust the high voltage supplies so that negative pulses with amplitudes of 1 volt or larger occur at a rate of the order expected for muon traversals (use Equation 3 to check this). Do not exceed 1850 V to keep the noise tolerable. Feed the pulses to the coincidence circuit. Examine the output of the coincidence circuit on the oscilloscope with the sweep speed set at $1 \mu\text{sec cm}^{-1}$, and be patient. You should occasionally see a decay pulse occurring somewhere in the range from 0 to 4 or so μsec , and squeezed into a vertical line by the slow sweep speed. Now feed the negative output of

the coincidence circuit directly to the STOP input and through an appropriate length of cable (to achieve the necessary delay as explained above) to the START input of the TAC. A suitable range setting of the TAC is 20.0 μsec , obtained with the range control on 0.2 μsec and the multiplier control on 100. Connect the TAC output to the MCA. Verify that most of the events are piling up on the left side of the display within a timing interval of a few muon lifetimes. Let some events accumulate and check that the median lifetime of the accumulated events is reasonably close to the half-life of muon. Calibrate the setup with the time calibrator.

Commence your measurement of muon decays. To record a sufficient number of events for good statistical accuracy you may have to run overnight or over a week-end. Plan your run so as to conform with the following schedule:

| Lab Section | Run Time |
|-------------|-------------------------------|
| Mon/Wed AM | Mon 4:00 PM to to Tue 9:00 AM |
| Mon/Wed PM | Wed 4:00 PM to Thu 9:00 AM |
| Tue/Thu AM | Tue 4:00 PM to Wed 9:00 AM |
| Tue/Thu PM | Thu 4:00 PM to Fri 9:00 AM |

In any case, leave a note on the experiment with your name, phone number, email and what the file is to be saved as. Friday is another possibility – be sure to sign up for the experiment!

If you have recorded a sufficient number of events, say several thousand, and if the background counts are a small fraction of the muon decay events near $t = 0$ then the pattern on the MCA screen should look like that shown in Figure (6).

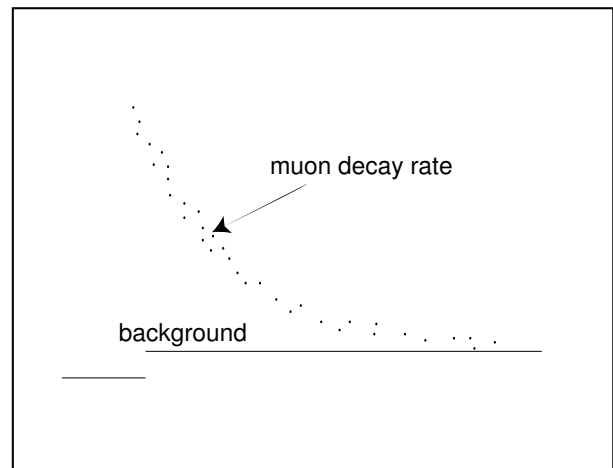

FIG. 6: Typical appearance on the MCA of the distribution in time of muon decays

There is a potential pitfall in the analysis. The distribution in duration of intervals between successive random pulses is itself an exponential function of the duration, with a characteristic "decay" time equal to the

reciprocal of the mean rate. If this characteristic time is not much larger than the muon lifetime, then the muon decay curve will be distorted and a simple analysis will give a wrong result. If the average time between events is much larger than the mean decay time, then you may assume that the probability of occurrence of such events is constant over the short intervals measured in this experiment, provided the triggering level is independent of the time since the last pulse. Under this condition, the observed distribution is a sum of a constant plus an exponential function of the time interval between the start and stop pulse. The constant, which is proportional to the rate of background events, is the asymptotic value of the observed distribution for large values of t . If this constant is subtracted from the distribution readout of the MCA, then the remainder should fit a simple exponential function the logarithmic derivative of which is the reciprocal of the mean life.

ANALYSIS

Sum the data in equal time intervals of a duration that is some sizable fraction of the apparent mean life, say $1/5$. This is easily done by manipulation of the cursors and the 'integration' feature of the Omega MCA. For example, you might begin with the start cursor on channel 101 and the stop cursor on channel 150. Record the number of counts registered in the interval. Then move 'both' cursors together so that the start cursor is on channel 151 and the stop cursor on channel 200, and record the number of counts, etc. You can derive a value of the muon mean life by first determining the background rate from the data at large times, and then fitting a straight line by eye to a hand drawn plot of the natural logarithms of the numbers of counts minus background in successive equal time bins versus the mean decay time in the interval. If you want to obtain the best possible results, try fitting the 3-parameter function

$$n_i = a e^{(-t_i/\tau)} + b \quad (13)$$

to your data by adjusting a, b , and τ by the method of least squares, i.e. by minimizing the quantity

$$\sum (n_i - m_i)^2 / m_i, \quad (14)$$

where m_i is the observed number of events in the i th time interval. (Watch out for faulty data in the first few tenths of a μsec due to lag in the recovery of the CFD, after pulsing of the photomultiplier, and the decay of negative muons that suffer loss by nuclear absorption.) Consult Melissinos (1966) for advice on error estimation.

Contemplate the fact of time dilation by addressing the following questions:

- How far does a high energy muon go in a time equal to the mean life of muons at rest?
- How long does it take a typical high energy cosmic-ray muon to get to sea level from its point of production? What would its survival probability be if its life expectancy were the same as that of a muon at rest?
- What would be the vertical intensity of muons at an altitude of 10 km given their observed intensity at sea level if all cosmic ray muons were produced at altitudes above 10 km and time dilation were not true. How does this value compare with the actual value measured in balloon experiments? (See Appendix A.)
- Calculate a typical value of the Lorentz factor γ at production of a muon that makes it to sea level and into the plastic scintillator.
- Problem: Suppose your twin engineered for you a solo round trip to Alpha Centauri (4 light years away) in which you felt a 11.0 g acceleration or deceleration all the way out and back (could you get out of your seat?). How much older would each of you be when you returned?

THEORETICAL TOPICS

1. The Special Theory of Relativity.
2. Energy loss of charged particles in matter.
3. Fate of negative muons that stop in matter.
4. Violation of parity conservation in muon decay.

GLOSSARY OF ACRONYMS

ADC analog to digital converter
 TC timing calibrator
 CFD constant fraction discriminator
 MCA multi-channel analyzer
 PHA pulse height analyzer
 PM photomultiplier
 TAC time to pulse height converter
 SCA single channel analyzer

APPENDIX A

PROPERTIES OF THE FLUX OF COSMIC-RAY MUONS

A particularly useful way to characterize the flux of cosmic-ray muons is to specify the distribution

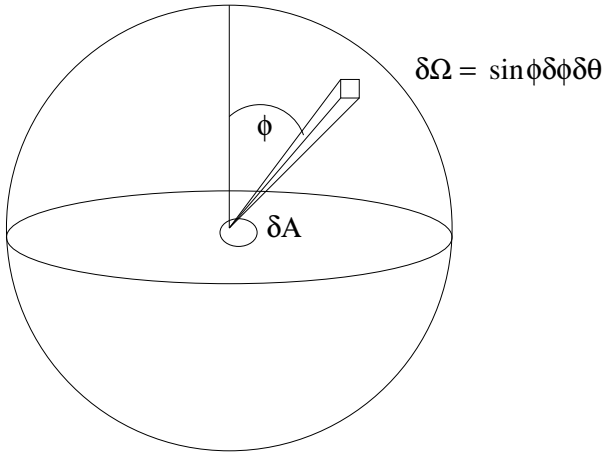

FIG. 7: Differential element of the flux of cosmic-ray muons.

$I(R, \varphi)$ of their residual ranges which we define so that $I(R, \varphi)dR d\Omega dA dT$ is the rate at which muons with residual range (measured in $g\text{ cm}^{-2}$) between R and $R+dR$ and zenith angle φ in the solid angle $d\Omega$ cross an area dA perpendicular to their direction in time dT .

Figure 10, extracted from a general review article by Rossi (1947) on the properties of cosmic rays, is a plot of the range distribution $I(R, 0)$ for vertical ($\varphi = 0$) muons at sea level. The distributions at other zenith angles can be represented fairly well by the empirical formula $I(R, \varphi) = I(R, 0) \cos^2 \varphi$. The stopping material in the experiment is a cylinder of scintillator plastic. Call its height b , its top area A , and its density ρ . Consider an infinitesimal plug of area dA in an infinitesimally thin horizontal slice of thickness (measured in $g\text{ cm}^{-2}$) $dR = \rho dx$ of the cylinder. The stopping rate of muons arriving from zenith angles near φ in $d\varphi$ in the element of solid angle $d\Omega$ in that small volume $dA dx$ can be expressed as

$$ds = I(R', 0) \cos^2 \varphi (\cos \varphi dA) (\rho dx / \cos \varphi) d\Omega \quad (15)$$

where $(\cos \varphi dA)$ is the projected area of the plug in the direction of arrival, $(dx / \cos \varphi)$ is the slant thickness of the plug, and R' is the residual range of muons that arrive from the vertical direction with just sufficient energy to penetrate through the overlying plastic to the elemental volume under consideration. The total rate S of muon stoppings in the cylinder can now be expressed as the multiple integral

$$S = 2\pi\rho \int_0^A dA \int_0^b I(R', 0) dx \int_0^{\pi/2} \cos^2 \varphi \sin \varphi d\varphi \quad (16)$$

in which we have replaced $d\Omega$ by $2\pi \sin \varphi d\varphi$ under the assumption of azimuthal symmetry of the muon intensity. According to Figure A1, the muon range spectrum

is nearly constant out to energies much greater than necessary to penetrate the building and the plastic. So we can approximate the quantity $I(R', 0)$ by the constant $I(R, 0)$. Performing the integrations and calling $m = Ab\rho$ the mass of the entire cylinder, one readily finds for the total rate of muons stopping in the cylinder the expression

$$S = \frac{2\pi}{3} m I(R_{av}, 0). \quad (17)$$

DISTRIBUTION OF DECAY TIMES

The fundamental law of radioactive decay is that an unstable particle of a given kind that exists at time t will decay during the subsequent infinitesimal interval dt with a probability $r dt$, where r is a constant characteristic of the kind of the particle and independent of its age. Call $P(t)$ the probability that a given particle that exists at $t = 0$ will survive till t . Then the probability that the particle will survive till $t + dt$ is given by the rule for compounding probabilities,

$$P(t + dt) = P(t)[1 - r dt]. \quad (18)$$

Thus

$$dP = -P r dt, \quad (19)$$

from which it follows that

$$P(t) = e^{-rt}. \quad (20)$$

To find the differential distribution of decay times $n(t)$, which is the distribution measured in the muon decay experiment with the TAC and MCA, we multiply the negative derivative of P by the product of the rate S at which muons stop in the scintillator by the total time T of the run. Thus

$$n(t) = (ST)(-dP/dt) = (ST) r e^{-rt}. \quad (21)$$

Identical reasoning can be applied to the problem of finding the distribution in duration of the intervals between random events that occur at a constant average rate s , like the background events in the muon decay experiment. In this case each random event that starts a timing operation, in effect, creates an 'unstable' interval (=particle) that terminates (=decays) at the rate s . Thus the distribution is a function of exactly the same form, namely

$$m(t) = (sT) s e^{-st}, \quad (22)$$

where (sT) is the expected total number of events in the time T . Note that the number of background events is proportional to s^2 . This suggests a limit on how low the discriminator can be set in an effort to catch all of the muon stopping events. At some point the ratio of muon decay events to background events will begin to decrease as s^2 .

APPENDIX C

-
- [1] P. R. Bevington & D. K. Robinson 1992, *Data Reduction and Error Analysis for the Physical Sciences*, 2nd Edition, McGraw Hill, QA278.B571 Physics Department Reading Room
- [2] A. French 1968, *Special Relativity*, Norton, QC6.F873 Physics Department Reading Room
- [3] A. C. Melissinos 1986, *Experiments in Modern Physics*, Academic Press, QC33.M523 Physics Department Reading Rom
- [4] A. Pais, *Subtle is the Lord... - The Science and the Life of Albert Einstein*, Oxford University Press, QC16.E5.P26 Physics Department Reading Room
- [5] B. Rossi 1948, *Rev. Mod. Phys.* 20, 537, QC.R455 Science Library Journal Collection
- [6] B. Rossi 1952, *High Energy Particles*, Prentice-Hall, Physics Department Reading Room
- [7] B. Rossi 1964, *Cosmic Rays*, McGraw-Hill, Physics Department Reading Room
- [8] E. Segri 1953, *Experimental Nuclear Physics*, Vol. I, Wiley, QC173.S4545 Science Library Stacks
- [9] Marshak, R.E. *Meson Physics*, p 191-201 New York,

McGraw-Hill, 1952

- [10] Frisch, D., and Smith, J.H. "Measurement of the Relativistic Time Dilation Using m -Mesons" from American Journal of Physics, Vol. 31 (1963) p 342-355
- [11] Hall, R.E., Lind, D.A., and Ristinen, R.A. "A Simplified Muon Lifetime Experiment for the Instructional Laboratory" from American Journal of Physics. Vol. 38 (1970) p 1196-1200