

Irradiation tests of voltage limiters

Ljubljana ATLAS group

October 2002

1. Introduction

The function of voltage limiter circuit is to protect the readout ASICs from overvoltage. Because of large voltage drop between power supplies and ASICs caused by long cables the voltage at the power supply output will be higher than maximum voltage allowed for ASICs. The absolute maximum for ABCD3T DMILL ASICs is 5.5 V while the voltage at power supplies will be higher than 8 V for longest cables. In an event of sudden current drop supply voltage at modules could exceed the maximum allowed for ASICs because the reaction time of power supply control is too long (few ms). The sudden current drops could be caused by e.g. changing front end biasing DACs from normal values to 0, by loss of clock in the digital part ... A dedicated circuit (voltage limiter) is therefore needed which will protect the ASICs against such events. The scheme of the limiter circuit planned to be used in the SCT is shown in Fig 1. Measurements of limiter functionality and response times with SCT hybrid can be found in the document <http://www-f9.ijs.si/~mandic/limiter/LimReport.pdf>.

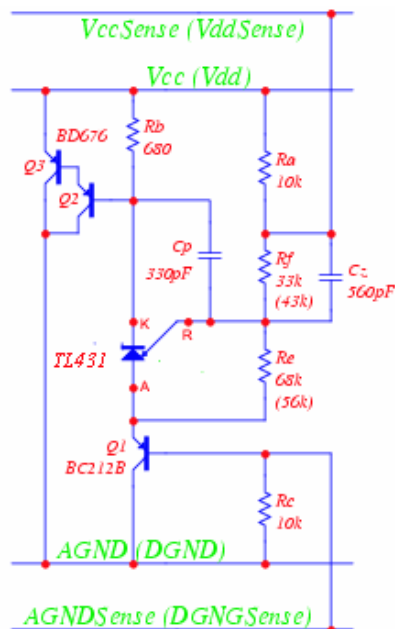

Fig 1. Voltage limiter schematic.

2. Radiation environment

The voltage limiter position will be at patch panel 3 (PP3) which is inside the experimental area. Any electronic component used inside UX15 must be tested for radiation hardness. Worst case radiation levels at PP3 position (R = 1200 cm, Z = 0 to 1000 cm) accumulated in 10 years of operation will be (see appendix):

- total ionization dose 300 rad,
- NIEL fluence in 1 MeV equivalent neutrons $\Phi_{\text{NIEL}} = 6 \times 10^{10} \text{ n/cm}^2$
- fluence of fast hadrons (E > 20 MeV, relevant for SEE) $\Phi_{\text{SEE}} = 1.2 \times 10^{10} \text{ p/cm}^2$

To these levels one has to apply several safety factors according to the "*ATLAS POLICY ON RADIATION TOLERANT ELECTRONICS*". Taking these into account, levels to which the circuit must be tested are:

1. total ionization dose 21000 rad,
2. fluence of 1 MeV NIEL equivalent neutrons $\Phi_{\text{NIEL}} = 1.2 \times 10^{12} \text{ n/cm}^2$
3. fluence of fast hadrons (E > 20 MeV, relevant for SEE) $\Phi_{\text{SEE}} = 2.4 \times 10^{11} \text{ p/cm}^2$

3. Components

The components used in the irradiated limiters (see also Fig 1):

- BD676 from SGS Thomson
- TL431 from SGS Thomson
- BC212B manufacturer unknown

4. Tests

Functionality of limiters was tested simulating conditions in ATLAS detector: power supply was connected to a load resistor over circuitry with capacitances and resistances similar to the situation in ATLAS experiment. With a switch the load resistance was steeply increased. This caused current drop which consequently would cause voltage increase on the load. This voltage increase must be controlled by the limiter.

In Fig 2 the simulation setup describing the measurement is shown. The load resistance is increased with the switch ST1 and voltage Vmod is monitored. Vmod must not exceed the limit set by the voltage limiter. This limiting voltage was measured on irradiated limiters.

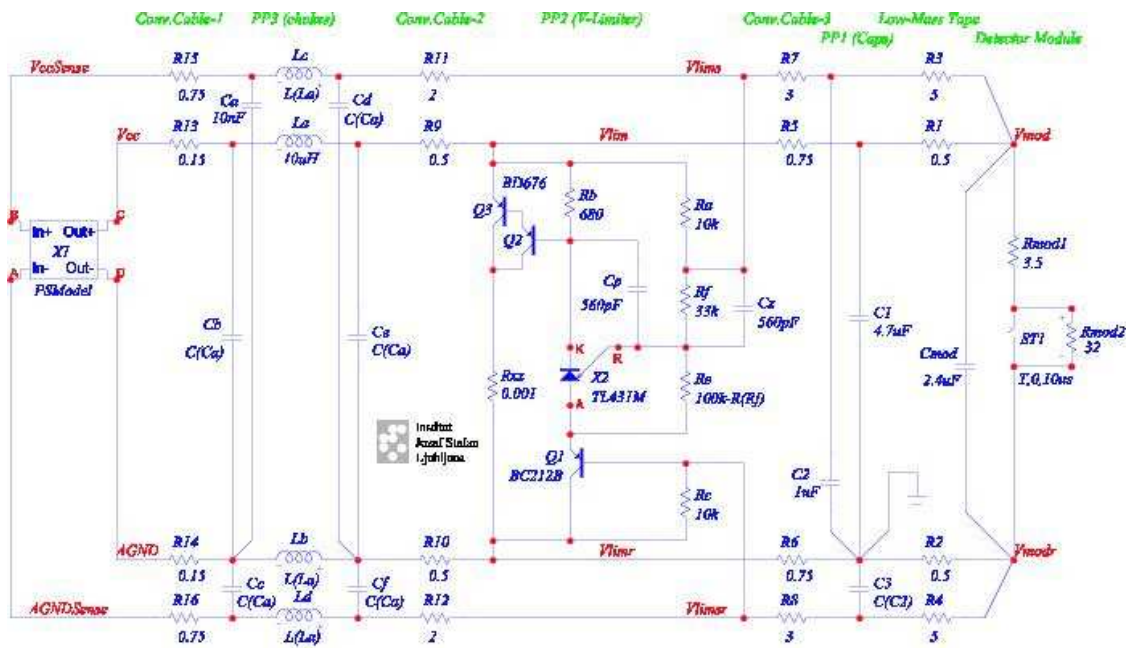

Fig 2. Simulation scheme of the limiter measurement setup

4. Results

Irradiations of limiters were done at reactor facility in Ljubljana (neutrons and ionization) and at the The Svedberg Laboratory in Uppsala, Sweden with 100 MeV protons. In the reactor limiters were first irradiated with neutrons to 6×10^{11} n/cm². Irradiation with ionizing dose was done by inserting the sample into reactor core while the reactor was not operating (i.e. fission was stopped). Therefore the sample was exposed only to radiation originating from the decay of fission products. Dosimetry was done with radfets. Radfets are MOS devices which measure the dose by measuring the threshold voltage shift caused by the charge trapped in the gate SiO₂.

Results of irradiation in reactor are summarized in Table 1. Irradiation with neutrons was done in two steps. In the first fluence was 2.5×10^{11} n/cm² and in the second 3.5×10^{11} n/cm² were added so that the total neutron fluence was 6×10^{11} n/cm². The irradiated limiters were then irradiated also with ionization dose of 35 krad. During neutron irradiation the limiters were exposed to around 5 krad so that the total dose received by the limiters was 40 krad. Measurements were done at power supply voltage $U = 6.8$ V, current through the load resistor was 0.63 A, current through the limiter (when not limiting) was 0.29 mA. In Fig 3 plots of limiting voltage (average for the 12 devices) as a function of neutron fluence and ionization dose is shown.

	$\Phi=0$	$\Phi=2.5e11$	$\Phi=6e11$	D=35 krad
Limiter No	Ulim0	Ulim1	Ulim2	Ulim3
1	4.90	4.92	4.94	5.06
2	4.91	4.94	4.94	5.06
3	4.91	4.94	4.95	5.07
4	4.92	4.94	4.94	5.06
5	4.92	4.94	4.96	5.07
6	4.91	4.92	4.96	5.03
7	4.89	4.91	4.92	5.01
8	4.90	4.91	4.93	5.02
9	4.87	4.88	4.89	4.90
10	4.90	4.94	4.96	5.02
11	4.81	4.84	4.96	4.91
12	4.90	4.93	4.96	5.03
Average	4.90	4.92	4.94	5.02

Table 1: Results of irradiation of limiters in the reactor in Ljubljana. Ionizing dose of 35 krad was added after neutron irradiation. Total ionizing dose received by the limiters was 40 krad.

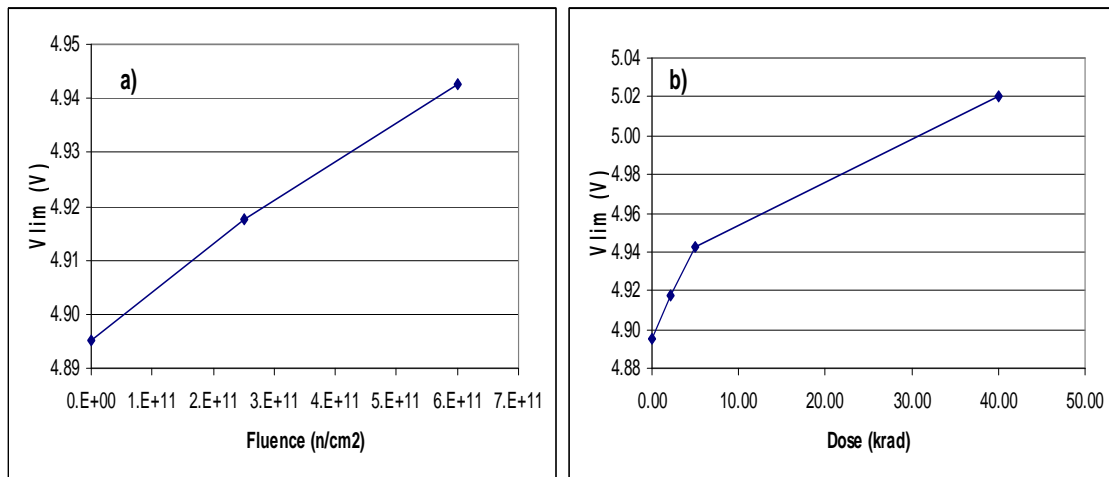

Fig 3. Left: limiting voltage as a function of neutron fluence (in 1 MeV NIEL equivalent neutron). Right: limiting voltage as a function of ionizing dose.

Results of proton irradiation are summarized in Table 2. Load resistors were at 3.5 V, power supply voltage was 7.8 V, load current was 0.75 A. Resistors in the limiters were chosen so that the limiting voltage was 4.5 V.

Load voltage (V_{mod}) was monitored also on a scope to observe transients due to eventual SEE in the limiter. No spikes exceeding the noise level (~ 100 mV) were observed which could be related to the beam.

In figure Fig 4. limiting voltage is shown as a function of proton fluence

Limiter No	U_{lim0}	U_{lim1}	Φ (p/cm ²)	D(rad)
1	4.52	4.58	2.70E+11	26000
2	4.51	4.57	2.70E+11	26000
3	4.49	4.75	1.00E+12	100000
4	4.51	4.78	1.00E+12	100000

Table 2: Results of irradiation of limiters in 100 MeV proton beam in Uppsala.

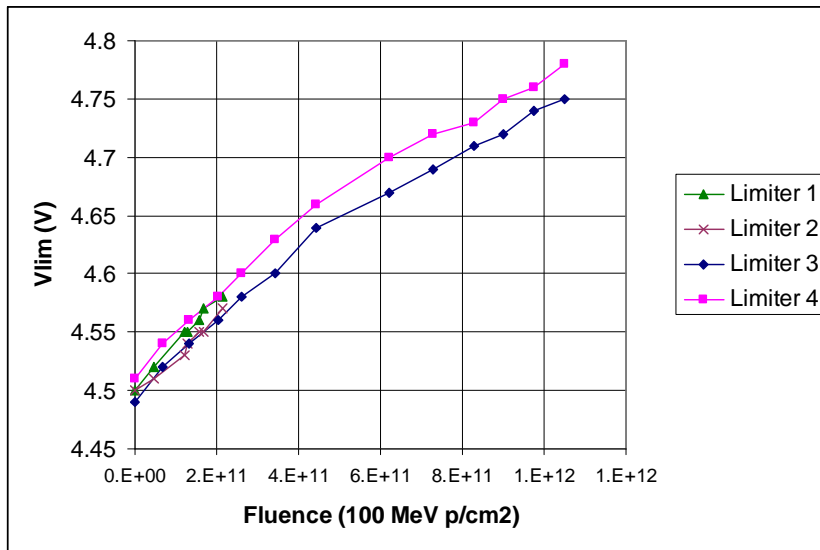

Fig 4 Limiting voltage as a function of proton fluence.

5. Conclusions

Voltage limiters were irradiated with 100 MeV protons, reactor neutrons and gamma rays. Limiters were fully functional after any of irradiations. Increase in voltage limit as a consequence of irradiation was measured. Limiting voltage increased by 0.1 V after $6 \times 10^{11} \text{ n/cm}^2$ and 40 krad of ionization dose and by 0.3 V after 10^{12} p/cm^2 (corresponding to $1.4 \times 10^{12} \text{ n/cm}^2$ and 100 krad of ionization dose).

From reactor irradiation results shown in Fig 3. it can be concluded that V_{lim} increase during neutron irradiation was mostly caused by displacement damage (and not by ionization dose received together with neutrons). By this we can explain the kink in the Fig 3b plot. Therefore, assuming that the limiting voltage increases linearly with NIEL fluence and dose, we can make an approximation that:

$$\Delta V_{NIEL} = \frac{0.04V}{6 \cdot 10^{11} \text{ n/cm}^2} = 6.7 \cdot 10^{-14} V / \text{ncm}^{-2} \quad (1)$$

$$\Delta V_{IONIZ} = \frac{0.08V}{35\text{krad}} = 2.3 \cdot 10^{-3} V / \text{krad} \quad (2)$$

Using these numbers the proton irradiation results can be cross-checked. With protons NIEL fluence delivered was $\Phi_{NIEL} = 1.3 \cdot 10^{12} \text{ n/cm}^2$ and the ionization dose was $D = 100 \text{ krad}$. If we assume that total voltage increase is a sum of increase caused by ionization dose and increase caused by NIEL than using numbers from (1) and (2) the prediction for limiting voltage increase for proton irradiation would be

$$\Delta V = 6.7 \cdot 10^{-14} V / \text{ncm}^{-2} \cdot 1.3 \cdot 10^{12} \text{ n/cm}^2 + 2.3 \cdot 10^{-3} V / \text{krad} \cdot 100\text{krad} = 0.31V$$

which is in good agreement with 0.25 V measured.

The NIEL radiation level to which the limiters were tested with protons was higher than maximum required (with all the safety factors) for position $R = 1200 \text{ cm}$ and total dose also exceeded the required level by large extent. Irradiation with protons also proved that the limiters are not susceptible to destructive single event effects. Taking into account also good consistency between irradiations in Ljubljana and Uppsala we conclude that limiting voltage will increase by less than 0.13 V after 10 years in ATLAS. Therefore voltage limiters are sufficiently radiation hard to be used at PP3.

APPENDIX

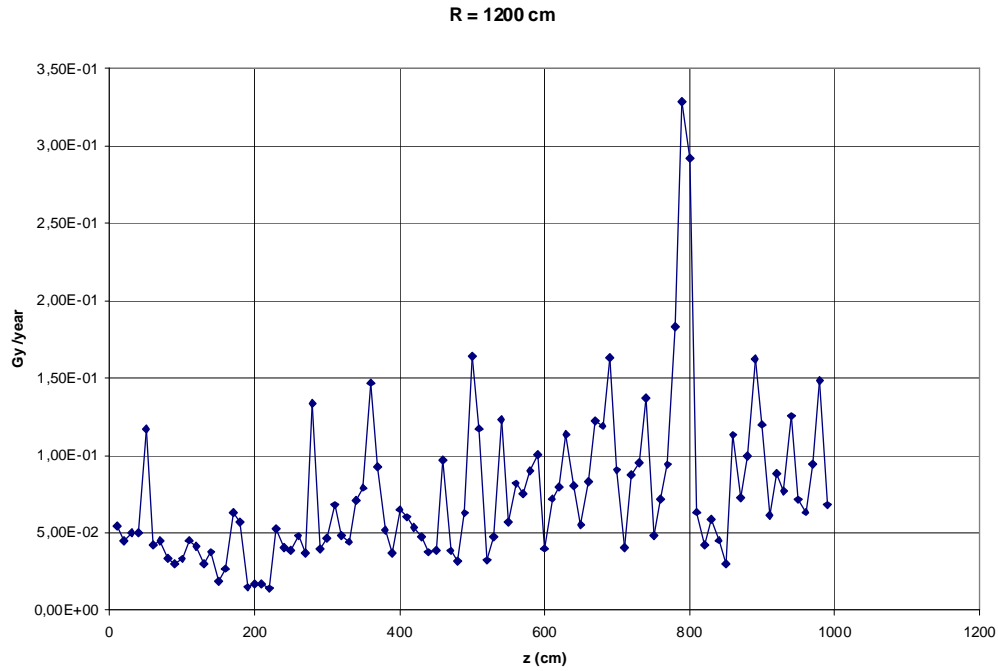

Fig 1 Calculated total dose in ATLAS experiment at R = 1200 cm

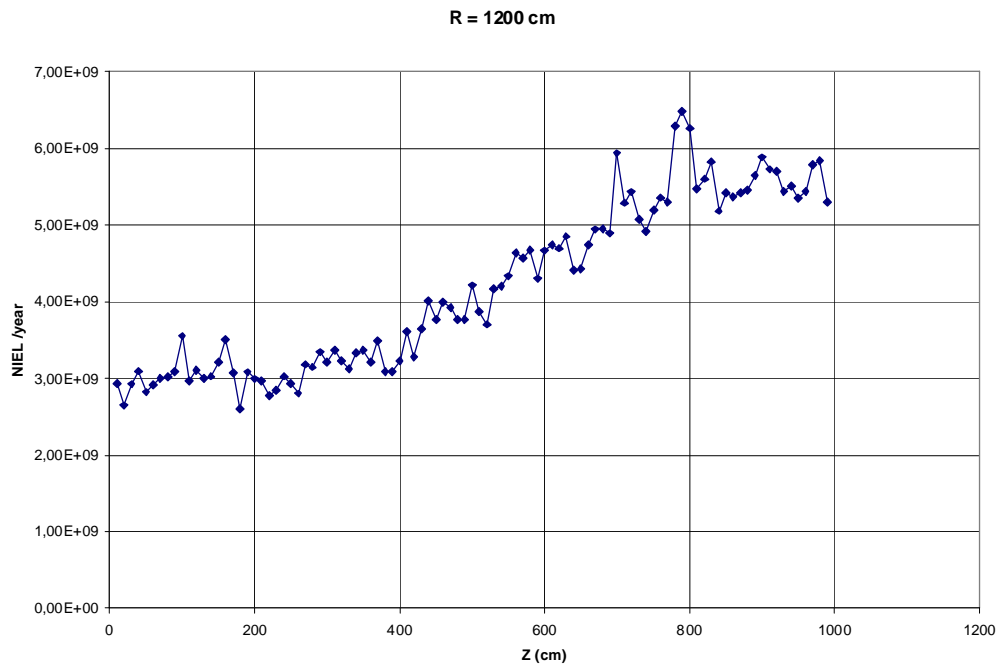

Fig 2 Calculated NIEL in ATLAS experiment at R = 1200 cm

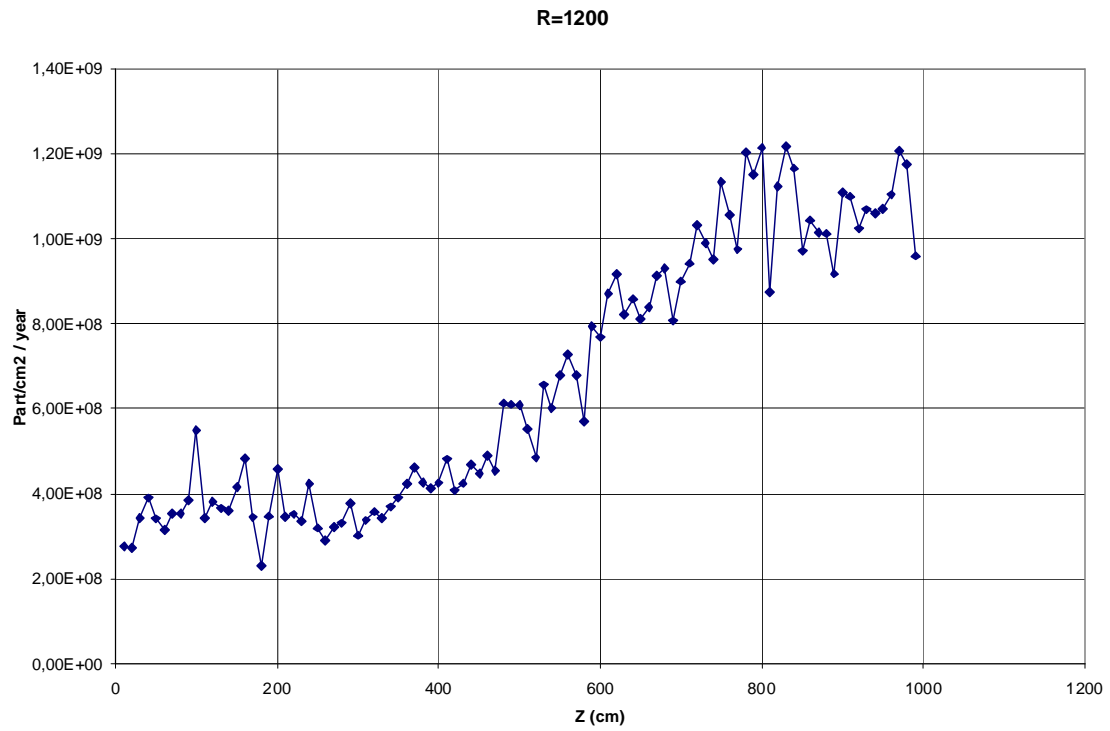

Fig 3. Calculated fluence of hadrons with energy $E > 20$ MeV in ATLAS experiment at $R = 1200$ cm.