

OLD NINO INPUT

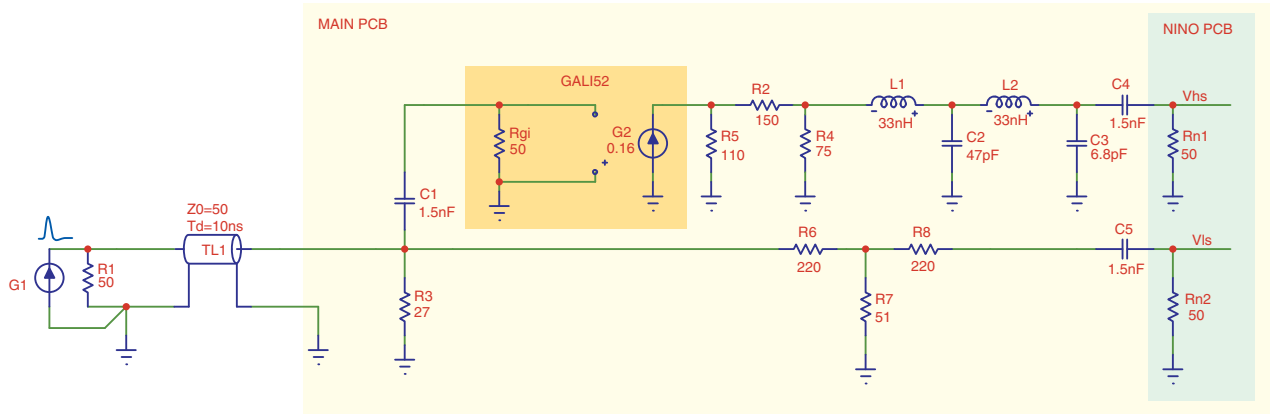

NEW NINO INPUT

Proposed around 18.06.2010; spare-box modified accordingly before 08.09.2010, but because of the overhead of keeping the system running it was tested only in 12.2010.

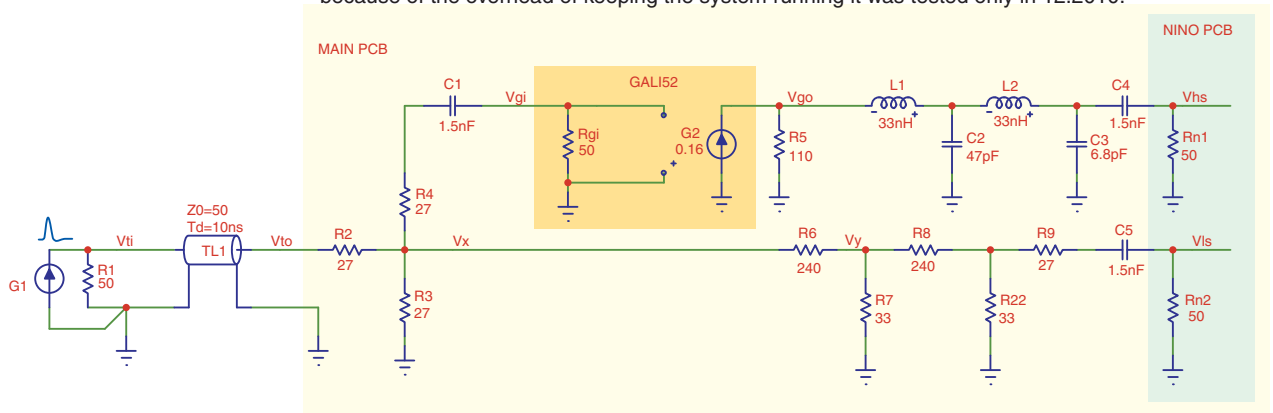

Difference: The attenuation from the GALI output has been moved to the input, and another resistive divider has been added to the low-sensitivity attenuation.

NEW NINO INPUT SIMULATION

